



# 50x50x20mm

- **Airflow: 8.9~14.0 CFM**
- **Static Pressure: 2.1~5.5 mm-H<sub>2</sub>O**
- **Blade / Housing: Plastic Material UL 94V-0 P.B.T.**
- **Lead Wire: UL1007 #26 AWG**
- **Weight: 36.0 g**

Model No.	Bearing	Rated Voltage VDC	Operating Voltage Range VDC	Speed RPM	Max. Airflow CFM	Max. Static Pressure mm-H <sub>2</sub> O	Current mA	Power Consumption W	Life at 40°C L10 Hour	P-Q Curve	Noise Level dB(A)
FD125020LS	S	12	7~13.2	3500	8.9	2.1	60	0.72	30000	3	22.5
FD125020MS	S		7~13.2	4300	11.0	4.0	90	1.08	30000	2	25.0
FD125020HS	S		7~13.2	5300	13.2	4.7	110	1.32	25000	1	30.0
FD125020LB	2B		7~13.2	3900	10.0	2.5	60	0.72	80000	3	23.5
FD125020MB	2B		7~13.2	4800	12.2	4.0	90	1.08	80000	2	28.0
FD125020HB	2B		7~13.2	5600	14.0	5.5	110	1.32	75000	1	32.5

2B: 2-ball bearing BS: 1-ball 1-sleeve bearing L: sintetico bearing S: sleeve bearing

**Voltage Available**

05 12 24 48

**Bearing System Available**

2B L S

**Function Available**

N A I F R Q S T M V C P D W U

**PERFORMANCE P-Q CURVE**

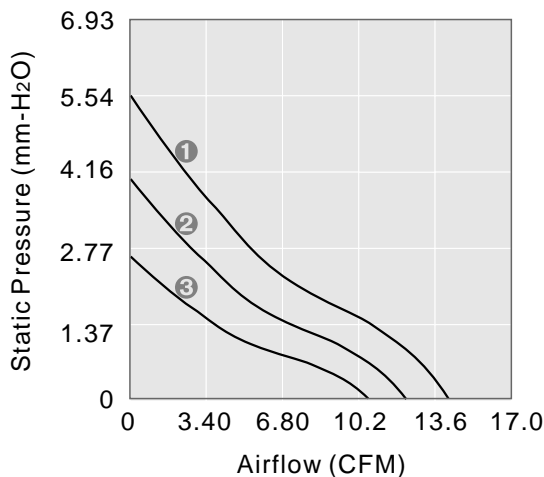

**OUTLINE DIMENSIONS**

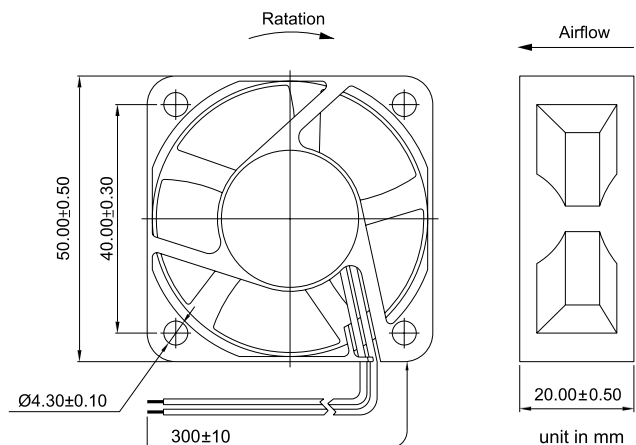

Please refer to *Model Numbering System* for bearing, function and speed level indication. Specifications are subject to changes without notice. Please refer to the formally issued product specification via contacting Y.S. TECH sales department. Visit Y.S. TECH web site at <http://www.ystech.com.tw> for updated information. Customized Specifications are designed accordingly.